

S2770RTE/S3370RTE/S3970RTE

ELECTRIC COMPACT ROUGH TERRAIN SCISSOR LIFTS



- Zero emission electric compact rough terrain scissor lift with lithium-ion batteries
- Excellent rough terrain performance
- Suitable for interior and exterior use
- Roll-out deck extension for extra reach
- Ideal for outdoor work in confined spaces



snorkel[™]
www.snorkellifts.com

ELECTRIC COMPACT ROUGH TERRAIN SCISSOR LIFTS

S2770RTE/ S3370RTE/S3970RTE

DIMENSIONS	S2770RTE*	S3370RTE*	S3970RTE*
Max. working height	10.1m	12.0m	13.8m
Max. platform height (A)	8.1m	10.0m	11.8m
Platform size (stowed) (B)	1.6m x 2.8m	1.6m x 2.8m	1.6m x 2.8m
Platform size (extended) (C)	1.6m x 4.0m	1.6m x 4.0m	1.6m x 4.0m
Extension deck length	1.2m	1.2m	1.2m
Overall width (D)	1.8m	1.8m	1.8m
Overall length (E)	3.4m	3.4m	3.4m
Stowed height (F)	2.61m	2.7m	2.95m
Min. height (guardrails folded)	1.83m	2.0m	2.13m
Ground clearance	330mm	330mm	330mm

PERFORMANCE			
Platform capacity (SWL)	580kg	450kg	350kg
Max. drive height	8.1m	10.0m	11.8m
Max. wind speed	12.5m/s	12.5m/s	12.5m/s
Max. drive speed (stowed)	4.5km/h	4.5km/h	4.5km/h
Max. drive speed (elevated)	0.5km/h	0.3km/h	0.3km/h
Raise/lower time	26/30 sec	50/60 sec	50/60 sec
Gradeability	35%	35%	35%
Max. stabilizer levelling, front to rear	6°	6°	6°
Max. stabilizer levelling, side to side	10°	10°	10°
Inside turning radius	2.7m	2.7m	2.7m
Outside turning radius	5.0m	5.0m	5.0m
Tires	27 x 10.5 15 foam filled, non-marking		
Controls	proportional joystick		
Drive system	4 wheel drive		

POWER	
Power source	Li-ion battery with integrated BMS
Operating temperature	(-) 25° C to (+) 60° C
Charger	High frequency smart on-board 50A battery charger

MOTOR	
Motor	AC electric motor

WEIGHT			
Weight	2,800kg	3,620kg	3,790kg

TURNING RADIUS

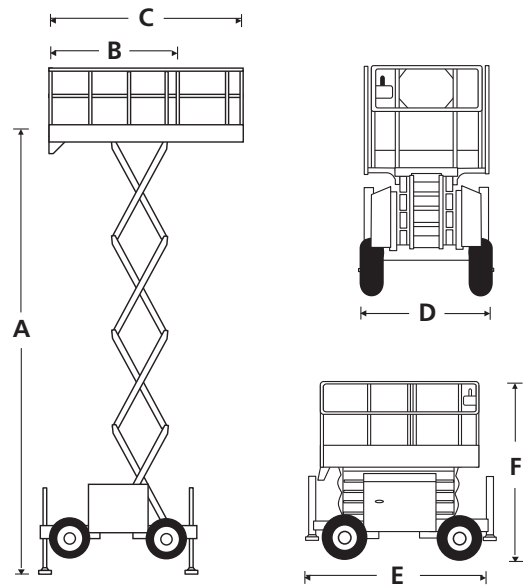
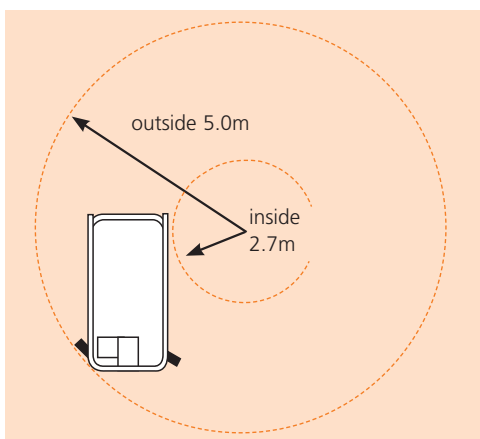

STANDARD FEATURES

- Two lithium-ion battery systems 11.5kWh
- 4 wheel drive
- Roll-out deck extension
- 4 hydraulic stabilizers with automatic levelling
- Non-marking foam filled tires
- Proportional controls
- Power line to platform
- Drive motion alarm
- Descent alarm
- Fold-down guardrails
- Flashing amber lights (2)
- Articulating axle
- Hour meter & on-board diagnostics display
- Manual lowering valve
- Dual lanyard attachment points
- 2000 charging cycles/2 year** lithium battery warranty
- 2 year parts & labor, 5 year structural warranty
- ANSI compliant

OPTIONS

- Special paint colors
- Additional 5.75kWh battery system
- Nylon spreader pads (set of 4)
- Environmental hydraulic oil

snorkel www.snorkellifts.com

P.O. Box 1160
St. Joseph, MO 64502-1160, USA
Tel: 1 (785) 989-3000
Toll-free: 1 (800) 255-0317
Fax: 1 (785) 989-3070
Email: sales.usa@snorkellifts.com